

General Specifications

Model UT750 Digital Indicating Controller (with Custom Computation)



GS 05D01B02-01E

General

Model UT750 Digital Indicating Controller is an intelligent, micro-processor based digital indicating controller with powerful control capability, custom computation function and the user-friendly large numerical display. The UT750 features many functions which are necessary for various control application as standard, and all of these functions such as control function, control computation function, signal computation function, etc. can be configured by using the keys on the front panel. The instrument specifies thirteen types of control strategies built in and also the overshoot suppressing function "SUPER" and a hunting suppressing function "SUPER 2" as well as an auto-tuning as standard.

Main Features

- Extra-large digital display allows the indicated values to be read even from a long distance. LEDs of 20 mm height are used for the process variable display. This is a five-digit display for higher resolution.
- User-friendly full dot LCD display. Not only the target setpoint and other control related parameters but also a deviation trend record or a deviation analogue bar can be displayed.
- Thirteen types of control function, including single-loop control, cascade control, loop control with PV auto-selector, and custom computation control, enabling the operator to start control operation immediately after simply entering the settings.
- Custom Computation function, which allows users' own configuration for signals, enable them to realize such functions as complicated computation for input compensation or sequence logic.
("Custom Computation Building Tool <model name: LL200> is necessary to use this function.)
- Universal input and output enable users to set or change freely the type of measured inputs (thermocouple, RTD, or DCV), measurement input range, type of control output (4 to 20mA current, voltage pulse, or relay contact), etc. from the front panel.
- Equipped with seven contact inputs and outputs each, which are further expandable up to 23 inputs and outputs each by adding contact I/O signal expansion modules.
- Various communication function are provided. Communication is possible with personal computer, programable logic controller, and other controllers.

Functional Specifications

Control Functions

UT mode

The following types of basic control structure can be set as the UT mode by the user.

- Single-loop Control (UT mode 1):
The most simple and basic control function.

UT750

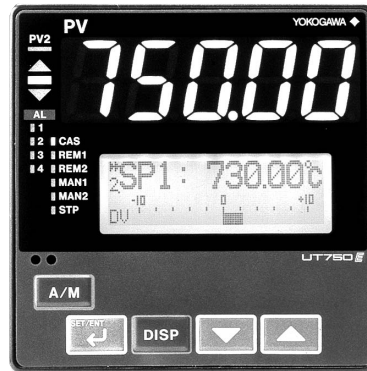

UT750E
"E" indicates with the model with expanded functions.

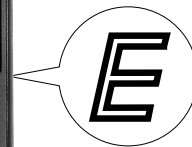

- Cascade primary-loop control (UT mode 2):
Output tracking function and cascade control logic are provided. Suitable for the primary-loop cascade control.
- Cascade secondary-loop control (UT mode 3):
Setpoint output and cascade control logic are provided. Suitable for the secondary-loop cascade control.
- Cascade control (UT mode 4):
Dual control function for cascade control is available in a single instrument.
- Loop control for back up (UT mode 5):
Output tracking function is provided to back-up another control instrument. The switching between its control output and the control output of the instrument to be backed-up can be carried out by external contact.
- Loop control with PV switching (UT mode 6):
Two measured inputs are switched for control depending on the status of contact input or measured input.
- Loop control with PV auto-selector (UT mode 7):
Two measured inputs are automatically selected for control with a high, low, average, or temperature-difference value selector.
- Dual-loop control (UT mode 11):
Dual control function is available in a single instrument to control two loop.
- Temperature and Humidity control (UT mode 12):
Temperature and Relative Humidity control is available in a single instrument.
- Cascade control with two universal inputs (UT mode 13):
Cascade control with using two universal measured inputs.
- Loop control with PV switching and two universal inputs (UT mode 14):
Loop control with PV switching and two universal inputs available as measured inputs.

Loop control with PV auto-selector and two universal inputs (UT mode 15):
 Process variable for loop control is automatically selected from two or three measured inputs by an internal selector, with using two universal inputs and an auxiliary analogue input. When two universal inputs are configured as measured input, auxiliary analog input can be used for a remote setting input.

Custom computation control (UT mode 21):
 Can be provided by the user using the optional LL200 custom computation building tool.

● **Control Computation Functions**

In each UT mode, the following control computation functions can be selected.

Continuous PID control, Time-proportional PID control, Position proportional PID control(UT750-1 □ position-proportional type only), Relay ON/OFF control, Heating/Cooling control.

Target setpoint and PID parameter:
 Maximum eight sets of target setpoint and PID parameters can be set and stored in a instrument. For Cascade control and Dual Loop control type, eight sets for each main and slave are available.

Zone PID selection:
 Sets of PID parameters can be selected according to PV zone. Maximum seven zones can be set for selection.

Auto-tuning:
 Available as standard.
 Possible to activate auto-tuning for both loops of Cascade control, Dual-loop control, and Temperature and humidity control.

“SUPER” function:
 Overshoots generated by abrupt changes in the target setpoint or by disturbances can be suppressed.

“SUPER 2” function:
 The function stabilizes the state of control that is unstable due to hunting, etc. without requiring any change in PID constants, when the load and/or gain varies greatly, or when there is a difference between the characteristics of temperature zones.

Preset output function:
 When the instrument is in STOP mode, measured input is burnout, or abnormality is found in an input circuit, users’ preconfigurable preset value is output as a control output.

Control cycle time:
 Each cycle time can be selected under the following conditions

50ms: Available when model code is "UT750-00", UT mode is set to Single-loop control, and the following function is not used. “SUPER” function, “SUPER 2” function, Heating/Cooling control, measured input computations, setpoint rate of change limiter, output rate of change limiter, deviation alarm, sensor grounding alarm, fault-diagnosis alarm, FAIL output.

100ms: Available when model code is UT750-0 □, UT750-1 □, (Without Cascade control)

200ms: Available when model code is UT750-5 □ and the amount of computation module of Custom computation function is less than 30.

500ms: Available when the amount of computation module of Custom computation function is more than 30.

(Set value on shipped from the factory: 200ms)

Operation Mode Switching

(Note: Communication enables all the following mode switching to be executed.)

AUTO/MANUAL switching:

Bump-less switching is available. Switching between AUTO and MANUAL mode can be realized by using front key or by external contact, and external contact switching has priority to a front key operation. When UT mode is set to “Cascade secondary-loop control” or “Cascade control”, switching can not be realized by external contact.

RUN/STOP switching:

Switching of RUN/STOP can be realized by external contact. Bump-less switching from STOP to RUN is available. In RUN mode, control computation is activated. In STOP mode, control computation is ceased and preset output value is output as a control output, while other functions are operated normally.

REMOTE/LOCAL switching:

Switching between local setpoints and remote setpoint can be realized by instrument operation or external contact, and external contact switching is prior to instrument operation. For remote to local switching, either with bump-less tracking (to make the local setpoint value equivalent to the Remote setpoint value upon switching.) or without tracking(to switch directly to local setpoint in the instrument) can be specified by the parameter.

CASCADE/AUTO/MANUAL switching:

Switching can be realized by instrument operation or external contact, and external contact switching is prior to instrument operation. Available when UT mode is set to “Cascade secondary-loop control” or “Cascade control” .

Output tracking ON/OFF switching:

Available when UT mode is set to “Cascade primary-loop control” or “ Loop control for back-up”. Switching between External tracking signal and internal control output can be realized by external contact.

Control Parameter Setting Range

Proportional band: 0.1 to 999.9%
 0.0 to 999.9% (for heating/cooling control.),
 0.0% available for ON/OFF control

Integral time: 1 to 6,000 s, or OFF (for Manual reset)

Derivative time: 1 to 6,000 s, or OFF

ON/OFF control hysteresis:
 0.0 to 100.0% of measured input range width

Preset output value: -5.0 to 105.0% of Output range
 (0mA or less cannot be output)

Output limiter:

Setting range: -5.0 to 105.0% for both high and low limits.

However, "low limit setpoint < high limit setpoint" must be satisfied.

When heating/cooling PID control, upper limiter for heating and upper limiter for cooling.

Shutdown function(For 4 to 20 mA control output only):

In manual mode operation, up to approx. 0mA can be output.

Rate of change limiter for output:

OFF, or 0.1 to 100.0%/s

Dead band of heating/cooling control:

-100.0 to 50.0% of Output value

Dead band of position-proportional control:

1.0 to 10.0 % of Output value

● Configuration of Input/Output Signal**Measured Input Computations**

Bias(-100.0 to 100.0% of measuring input range), First lag filter(OFF, 1 to 120 s), Square root extraction(for voltage input only, Input low cut 0.0 to 5.0%), 10-segment linearizer function, 10-segment bias function, relative humidity calculation by wet/dry bulb(for Temperature & Humidity control type)

Auxiliary Input Computations

Applicable for remote setting input only.

Bias(-100.0 to 100.0%), First lag filter (OFF, 1 to 120s), Square root extraction (Input low cut 0.0 to 5.0%), Ratio multiplication (0.001 to 9.999)

Custom Computations

LL200 Building tool is necessary to use Custom computation function.

Combining computation function modules allows such functions as users' own configuration of input/output signals, operation mode switching via contact input, and status output via contact output.

Computation function module:

Addition/subtraction/multiplication/division, Processing absolute value/reciprocal, Selecting maximum/minimum/average, Keeping maximum/minimum value, Keeping value, Rate of change limiter, Switch, Limiter, Constant, AND, OR, Exclusive OR, NOT, Latch, Comparison (=, <, >, ≤, ≥), Not equivalent, Within range, AND(word), OR(word), Shift word, Sum, Timer, Ten-segment linearizer 1/2, Inverse ten-segment linearizer 1/2, Curve linearizer 1/2, Ratio, First order lag filter, Conversion to industrial unit, Selection of PV from two inputs, Temperature and humidity calculation, MV selection 1/2, Conversion of display value, Parameter setting, Data display 1/2, Special contact output calculation, Assignment of output terminals 1/2, etc.

Maximum usable Number of Module:

Input custom computation 50

Output custom computation 50

● Alarm Functions**Alarm types:**

PV high limit, PV low limit, Deviation high limit, Deviation low limit, Deenergized on deviation high limit, Deenergized on deviation low limit, Deviation high and low limits, High and low limits within deviation, Deenergized on PV high limit, Deenergized on PV low limit, SP high limit, SP low limit, Output high limit, Output low limit.

Alarm setting range:

PV/SP alarm: -100 to 100 % of measured input range

Deviation alarm: -100 to 100 % of measured input range width

Output alarm: -5.0 to 105.0% of output value

Alarm hysteresis: 0.0 to 100.0 % of measured input range width

Delay timer:

0.00 to 99.59 (minute, second)

An alarm is output when the delay timer expires after the alarm setpoint is reached.

Setting for each alarm is possible.

Stand-by action:

Stand-by action can be set to make PV/ deviation alarm OFF during start-up or after SP change until SP reaches the normal region.

Timer function (stabilization of control status notification event) (Alarm 1 only):

The timer function sets alarm 1 output to ON/OFF when preset time is elapsed after PV has reached to the SP and its hysteresis band.

Activated again by RUN/STOP switching or SP switching.

Other alarm actions:

Sensor grounding alarm: Detects sensor deterioration and outputs an alarm.

Fault diagnostic alarm: Input burnout, A/D conversion error, RJC error.

FAIL output: Abnormality in software, or Abnormality in hardware.

Number of alarm settings: 4 points (for each loop)**Alarm output points: 4 points**

Up to 4 points can be selected among PV, deviation, SP, output sensor grounding, fault diagnosis and FAIL alarms and output.

Timer function is available with alarm 1 output only.

Note: See the Hardware Specifications and the contents of Contact Outputs described later.

● Display and Operation Functions**PV Display Unit**

Either PV1 or PV2 can be displayed on 5 digit digital display unit and switched one from the other.

Digit of display is 4 or 5 digit. For Thermocouple and RTD input, Lower digit than decimal point can be turned off.

The display range is -19999 to 30000 and the display span is 30000 or less. [750.00 appearing in the product photograph on page 1 cannot actually be displayed.]

LCD Display Unit

Some data are displayed on LCD display unit. Each screen is called “display”.

Four types of displays are provided. Operating display, Operating parameter setting display, setup parameter setting display, and SELECT display.

Each screen of LCD display unit

Operating display:

Necessary data for operation is displayed according to UT mode. Such items as Setpoint, Control output, Control output bar-graph, deviation trend, and deviation analogue bar-graph are displayed. Memorable time of deviation trend is 120 s to 20 h.

Operating parameters setting display:

The Operating parameters, which are mainly changed during operation, such as PID constant, are displayed.

Setup parameter setting display:

The Setup parameters to configure the functions of the instrument before starting operation are displayed. UT mode is set in this display.

SELECT display:

Up to 5 displays which are frequently accessed can be selected from the Operating parameter setting display and Setup parameters setting display to be displayed in the SELECT display.

Status Lamps

Alarm indicating lamp: 4 points(AL1,AL2,AL3,AL4)

Operation mode indicating lamp:

PV 2 (PV of Loop 2), REM 1 (Remote operation of Loop 1), REM 2 (Remote operation of Loop 2), MAN 1 (Loop 1 in Manual mode operation), MAN 2 (Loop 2 in Manual mode operation), STP (Operation is ceased), CAS (Cascade operation)

Deviation indicating lamp:

▲ Plus deviation, ▼ Minus deviation, and ■ deviation in normal range

Deviation band for the display can be set.

Status lamps
Second PV (PV2), deviation (▲, ■, ▼)
Alarm (AL1,2,3,4), Cascade (CAS), Remote (REM1,REM2), Manual (MAN1,MAN2), Stop (STP)

Communication port for light loader
Communicate with the tool on the PC to transfer the setting data of parameters / Custom computation.

Operation keys
Increase/Decrease the setting data (Δ, ▽)
Switching the display (DISP)
Select parameter/Enter the setting data (SET/ENT)
A/M mode switching of Loop 1 (A/M).

LED display unit (for PV)
Display PV, and error code when error is detected.

LCD display unit
Display setpoint (SP), output value, deviation bargraph, deviation value, deviation trend, valve opening and setting item/value of parameters.

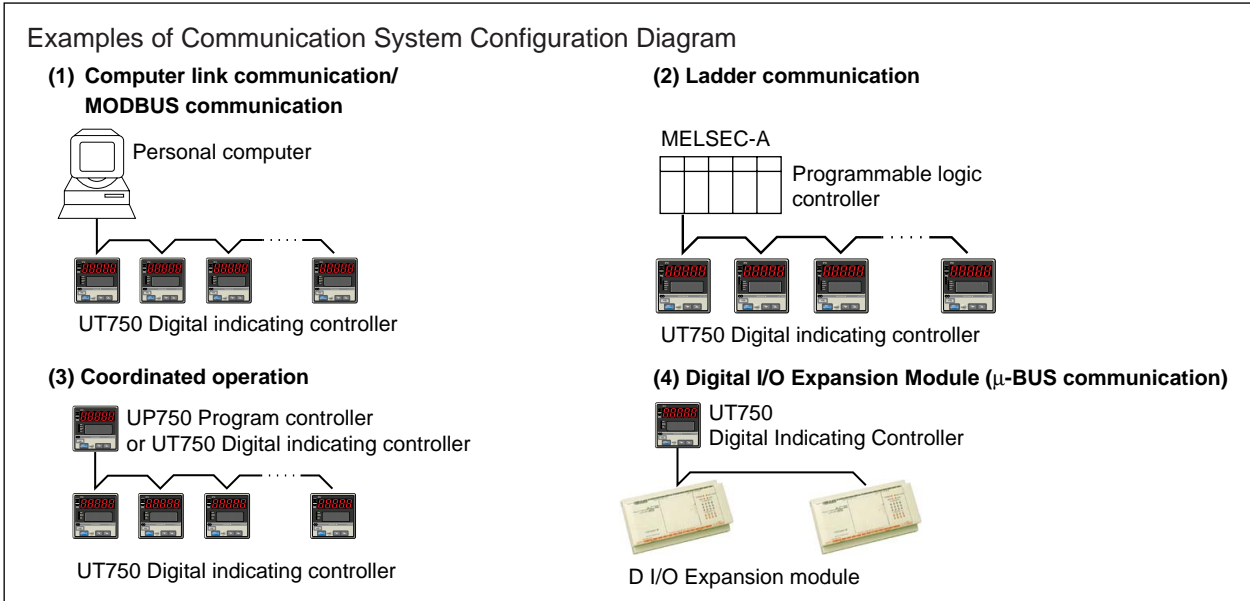

Operation Keys

- △, ▽ key: Increases/decreases the value of Setpoints or other parameters which appear on LCD display.
- DISP key: Switch data to be showed on LCD display
- SET/ENT key: Set/change the setting value, switch contents to be showed on LCD display, switch operation mode other than AUTO/MAN.
- A/M key: Switch operation mode (AUTO/MAN)

Security Function

Key lock from parameter setting and operation can be inhibited by a password.

● Communication Functions

(For UT750- □1 only)

The instrument has two communication port and five types of communication protocols, and allows the simultaneous communication with two different instruments.

The instruments to communicate are a personal computer, a programmable logic controller, and other UT750/UP750.

Communication Protocol

- Computer link communication: Communication protocol with a personal computer.
- Ladder communication: Communication protocol with the ladder program on some programmable logic controllers.
- Coordinated operation protocol: Protocol to realize Coordinated operation with other GREEN SERIES controller. UT750 can be configured as either master or slave unit.
- MODBUS communication: Communication protocol with a personal computer or PLC.
- Digital input/output expansion (μ-Bus): Protocol to connect Digital I/O expansion module to increase the number of Discrete Input and Output.

Input type	Input range code	Instrument range (°C)	Instrument range (°F)	Instrument accuracy*1		
Unspecified (When shipped from the factory)		OFF	Set the data item PV input type "IN 1" to the OFF option to leave the PV input type undefined.			
Thermocouple	K	typeK1 (1)	-270.0 to 1370.0°C	-450.0 to 2500.0°F	±0.1% ±1 digit of instrument range at 0°C or more ±0.2% ±1 digit of instrument range at less than 0°C • However, ±2% ±1 digit of instrument range for type K at temperatures less than -200°C. • However, ±1% ±1 digit of instrument range for type T at temperatures less than -200°C.	
		typeK2 (2)	-270.0 to 1000.0°C	-450.0 to 2300.0°F		
		typeK3 (3)	-200.0 to 500.0°C	-200.0 to 1000.0°F		
	J	typeJ (4)	-200.0 to 1200.0°C	-300.0 to 2300.0°F		
		T	typeT1 (5)	-270.0 to 400.0°C		-450.0 to 750.0°F
	typeT2 (6)		0.0 to 400.0°C	-200.0 to 750.0°F		
	B	typeB (7)	0.0 to 1800.0°C	32 to 3300°F		±0.15% ±1 digit of instrument range at 400°C or more ±5% ±1 digit of instrument range at less than 400°C
	S	typeS (8)	0.0 to 1700.0°C	32 to 3100°F		±0.15% ±1 digit of instrument range
	R	typeR (9)	0.0 to 1700.0°C	32 to 3100°F		
	N	typeN (10)	-200.0 to 1300.0°C	-300.0 to 2400.0°F		±0.1% ±1 digit of instrument range ±0.25% ±1 digit of instrument range for temperature at less than 0°C
	E	typeE (11)	-270.0 to 1000.0°C	-450.0 to 1800.0°F		±0.1% ±1 digit of instrument range at 0°C or more ±0.2% ±1 digit of instrument range at less than 0°C
	L (DIN)	typeL (12)	-200.0 to 900.0°C	-300.0 to 1600.0°F		• However, ±1.5% ±1 digit of instrument range for type E at temperature less than -200°C.
	U (DIN)	typeU1 (13)	-200.0 to 400.0°C	-300.0 to 750.0°F		
		typeU2 (14)	0.0 to 400.0°C	-200.0 to 1000.0°F		
W (DIN)	typeW (15)	0.0 to 2300.0°C	32 to 4200°F	±0.2% ±1 digit of instrument range		
Platine1 2	plati2 (16)	0.0 to 1390.0°C	32.0 to 2500.0°F	±0.1% ±1 digit of instrument range		
PR20-40	PR2040 (17)	0.0 to 1900.0°C	32 to 3400°F	±0.5% ±1 digit of instrument range at 800°C or more Accuracy not guaranteed for temperature less than 800°C		
W97Re3-W75Re25	W97Re3 (18)	0.0 to 2000.0°C	32 to 3600°F	±0.2% ±1 digit of instrument range		
RTD	JPt100	JPt1 (30)	-200.0 to 500.0°C	-300.0 to 1000.0°F	±0.1% ±1 digit of instrument range (Note 1) (Note 2)	
		JPt2 (31)	-150.00 to 150.00°C	-200.0 to 300.0°F	±0.2% ±1 digit of instrument range (Note 1)	
	Pt100	Pt1 (35)	-200.0 to 850.0°C	-300.0 to 1560.0°F	±0.1% ±1 digit of instrument range (Note 1) (Note 2)	
		Pt2 (36)	-200.0 to 500.0°C	-300.0 to 1000.0°F		
		Pt3 (37)	-150.00 to 150.00°C	-200.0 to 300.0°F	±0.2% ±1 digit of instrument range (Note 1)	
Standard signal	0.4 to 2V	0.4 to 2V (40)	0.400 to 2.000 V	Display range -19999 to 30000 Display span 30000 or less (Decimal point position changeable)	±0.1% ±1 digit of instrument range	
	1 to 5V	1 to 5V (41)	1.000 to 5.000 V			
DC voltage	0 to 2V	0 to 2V (50)	0.000 to 2.000 V			
	0 to 10V	0 to 10V (51)	0.00 to 10.00 V			
	0.00 to 1.25 V (Note 3)	0.00 to 1.25 V(52)	0.000 to 1.250 V			
	-10 to 20mV	mV1 (55)	-10.00 to 20.00 mV			
	0 to 100mV	mV2 (56)	0.0 to 100.0 mV			

Numbers in () are the measurement input range codes that apply when the communication function is used.

- *1: Performance in the standard operating conditions (at 23±2°C, 55±10% RH, and 50/60Hz power frequency)
- Note 1: The accuracy is ±0.3°C of instrument range ±1 digit for a temperature range from 0 to 100°C
- Note 2: The accuracy is ±0.5°C of instrument range ±1 digit for a temperature range from -100 to 200°C.
- Note 3: 0.0 to 1.2 V DC range is for universal input 2 (41, 42 and 43 terminals) only.

RS-485 Communication Interface

Two types of RS-485 communication interface (conforms to EIA RS485) available; High performance interface and general purpose interface. Both interfaces are available spontaneously according to usage.

High Performance Communication Interface:

High performance RS-485 communication is available with Computer link, Ladder, Digital input/output expansion module communication or Coordinated operation communication.

Specification (Common for Computer link, Ladder, and Coordinated operation):

Maximum number of connectable controllers: 31 units

Maximum communication distance: 1,200m

Communication method:

Two-wire half duplex, Start-stop synchronization system, Protocol free

Communication rate:

600,1200,2400,4800,9600bps,19.2k,38.4kpbs.

Digital I/O Expansion Module Communication (μ -Bus):

Digital I/O expansion module communication terminals are same as high performance communication terminals.

Digital I/O Expansion module:

P2ER1-20J, P2ET1-20J

Units to be connected: 2 units max.

Maximum communication distance: 15m max.

Communication rate: 1.25Mbps

General Purpose Communication Interface:

General purpose communication is available with Computer link, Ladder, MODBUS communication, or Coordinated operation.

Specification (Common for Computer link, Ladder, and Coordinated operation)

Maximum number of connectable controllers: 31 units

Maximum communication distance: 1200m

Communication method:

Two-wire half duplex or four-wire half duplex, Start-stop synchronization system, Protocol free

Communication rate:

600,1200,2400,4800,9600bps

Hardware Specifications**Input /Output Signal Specifications****Measured Input Signal**

Number of input: 1 or 2 points

Input type, measurement range and measurement accuracy:

Refer to the table on page 5.

Possible to select input type/measurement range by using front key or software.

Sampling period (RTD): 50, 100, 200, or 500 ms (selectable by software)

Initial value: 200 ms

Burnout detection:

Available with Thermocouple, RTD, standard signal 0.4 to 2 V and 1 to 5V input. Possible to detect upscale, downscale and off.

For standard signal, 0.1V or less are regarded as burnout.

Input bias current: 0.05 μ A (For T/C and RTD b terminal)

Specified current (RTD): about 0.13 mA

Input resistance:

TC/mV input: 1M Ω or more

DC Voltage input: Approx. 1M Ω

(0.0 to 1.2 V DC range for universal input 2:

Approx. 8M Ω)

Allowable signal source resistance:

TC/mV input: 250 Ω or less

Effect from allowable signal source resistance: 0.1 μ V/ Ω or less

DC Voltage input: 2k Ω or less

Effect from allowable signal source resistance: Approx. 0.01%/100 Ω

Allowable leadwire resistance:

RTD 150 Ω or less /wire (Lead resistances of three wires must be equal.)

For -150.0 to 150.0 $^{\circ}$ C range, 10 Ω /wire

Effect of wiring resistance: $\pm 0.1^{\circ}$ C/10 Ω

Allowable input voltage:

TC/mV/RTD: ± 10 V DC

DC Voltage: ± 20 V DC

Noise rejection ratio:

Normal mode: 40dB(50/60Hz) or more

Common mode: 120dB(50/60Hz) or more

RJC Error:

$\pm 1.0^{\circ}$ C(15 to 35 $^{\circ}$ C),

$\pm 1.5^{\circ}$ C(0 to 15 $^{\circ}$ C, 35 to 50 $^{\circ}$ C)

Applicable standard:

TC/RTD: JIS/IEC/DIN (ITS-90)

Response time: 1 second or less, 63% (10 - 90%)

(The time required for transmission output to reach 63% of the maximum excursion when PV abruptly changes from 10% to 90%)

Auxiliary Analogue Input (UT750-□1only)

Functions: Remote setpoint, Compensatory input, PV input of Cascade secondary-loop, etc.

Input type: DC voltage input 0 to 2 V DC, 0 to 10V DC, 0.4 to 2.0V DC or 1 to 5V DC (Settable within the range)

Number of input: 1 point

Sampling period: 100, 200 or 500 ms

auxiliary analog input period is linked with PV input period.

(when PV input period is 50 ms, auxiliary analog input period is 100 ms)

Input resistance: Approx. 1M Ω

Input accuracy: $\pm 0.3\% \pm 1$ digit of F.S. for 0 to 2 V DC range

$\pm 0.2\% \pm 1$ digit of F.S. for 0 to 10 V DC range

$\pm 0.375\% \pm 1$ digit of F.S. for 0.4 to 2.0 V DC range

$\pm 0.3\% \pm 1$ digit of F.S. for 1 to 5 V DC range

Performance in the standard operating conditions (at 23 $\pm 2^{\circ}$ C, 55 $\pm 10\%$ RH, and 50/60Hz power frequency)

Feedback Resistance Input

(For UT750-1□ only. Valid for Position proportional PID control)

Slidewire resistance whole resistance 100 Ω to 2.5 k Ω

(Detection of slidewire breaking is available), measuring span resistance is settable within the above range.

Measuring solution $\pm 0.1\%$ of whole resistance

Retransmission Output

One of measured value, setpoint, and control output is output as an analogue current signal. Selection must be done between 15 V DC loop power supply.

- Number of output: 1 or 2 points (depend on selection of control output)
- Retransmission output 2 is available only when “relay” is selected as the control function.
- Output signal: 4 to 20mA DC, 0 to 20mA DC, 20 to 4 mA DC or 20 to 0 mA DC (0 mA or less cannot be output)
- Load resistance: 600 Ω or less
- Output accuracy: ±0.1% of output span (±5% for 1 mA or less)
- Performance in the standard operating conditions (at 23±2°C, 55±10% RH, and 50/60Hz power frequency)

When using for 1.5V DC loop power supply:

- Supply voltage 14.5 to 18.0 V DC, maximum supply current about 21 mA (with the protection circuit at field short-circuit).

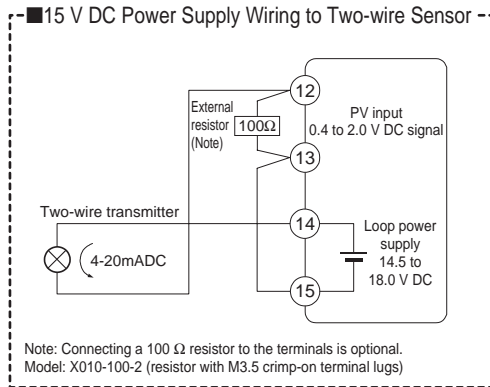

Control Outputs

One or two points can be selected from the following types, according to the model codes and specified UT mode. Just a relay contact output is available for Position-Proportional PID model(UT750-1□)

- Current output**
 - Number of output: 1 or 2 points (for heating/cooling control) (selected between voltage pulse output)
 - Output signal: 4 to 20mA DC, 0 to 20mA DC, 20 to 4 mA DC or 20 to 0 mA DC
 - Load resistance: 600 Ω or less
 - Output accuracy: ±0.1% of output span (±5% for 1 mA or less)
 - Performance in the standard operating conditions (at 23±2°C, 55±10% RH, and 50/60Hz power frequency)
- Voltage pulse output**
 - Number of output: 1 or 2 points (for heating/cooling control) (selected between current output)
 - Output signal: ON voltage 12V DC or more (Load resistance 600 Ω or more ; current on short-circuiting about 30mA), OFF voltage 0.1V DC or less
 - Resolution: 10ms or 0.1% of output value, whichever is greater
- Relay contact output**
 - Number of output: 1 or 2 points

- Output signal: Three terminals (NC, NO, and common)
- Contact rating: 250V AC 3A or 30V DC 3A (Load resistance)
- Resolution: 10ms or 0.1% of output value, whichever is greater

Contact Inputs

- Usage: Setpoint switching, C/A/M mode switching, REMOTE/LOCAL switching, RUN/STOP switching, measured input switching, message interruption display.
- Number of input: 7 points, max. 32 points (when Expansion Digital I/O connected)
- Input type: Non-voltage contact input or transistor open collector input
- Input contact rating: 12V DC, 10mA or more
- ON/OFF detection
 - For non-voltage contact input
 - ON=contact resistance 1kΩ or less,
 - OFF=contact resistance 20kΩ or more
 - For transistor input
 - ON=2V or less,
 - OFF=leak current 100µA or less
- Minimum detecting time: PV input sampling period ×3

Contact Outputs

- Usage: Alarm output, FAIL output, Cooling side output for Heating/Cooling control(Transistor contact output), Event output.
- Number of output: 7 points (Relay output 3 points, Transistor contact output 4 points)
- Relay contact rating: 240V AC 1A or 30V DC 1A (common to COM terminal)
- Transistor contact rating: 24V DC 50mA (common to COM terminal)

Expansion Digital I/O

Up to two Digital I/O expansion modules can be connected to increase the number of Digital I/O.
Each 8 points of input/output per one module can be accessed from the instrument.

● **Display Specifications**

- Measured value (PV) display: 5 digit seven segment red color LED display, height of the letter: 20mm
- Data display: 32 × 128 dot LCD display with back-light
- Status indicating lamps: LED

● **Conformance to Safety and EMC Standards**

- Safety: Compliant with IEC/EN61010-1: 2001, approved by CSA1010, approved by UL508.
- Installation category : CAT. II (IEC/EN61010, CSA1010) Pollution degree : 2 (IEC/EN61010, CSA1010)
- Measurement category : I (CAT. I : IEC/EN61010)
- Rated measurement input voltage : 10V DC max.(across terminals), 300V AC max.(across ground)
- Rated transient overvoltage : 1500V (Note)
- Note : It is a value on the safety standard which is assumed by IEC/EN61010-1 in measurement category I, and is not the value which guarantees an apparatus performance.

EMC standards: Complies with EN61326

During test, the controller continues to operate with the measurement accuracy within $\pm 20\%$ of the range.

● Construction, Installation, and Wiring

Construction: Dust-proof, Drip-proof Front panel conforming to IP55.

For side-by-side close installation, controller loses its dust-proof and drip-proof protection.

Material of the body:

ABS resin and polycarbonate

Case color: Black

Weight: Approx. 1kg

Dimensions: 96W×96H×100D (From the front panel surface) (mm)

Mounting: Direct panel mounting; mounting bracket, one each for upper and lower mounting

Panel cutout dimensions:

$92^{+0.8}_0$ W× $92^{+0.8}_0$ H (mm)

Mounting position:

0° to +30° with respect to vertical panel surface.

Wiring: M3.5 screw terminal (signals, power supply/ground)

● Power Supply and Isolation

Power supply: Rated voltage 100 to 240V AC, ($\pm 10\%$), 50/60Hz

Power consumption: MAX.20VA (MAX.8.0W)

Memory backup: Litium Battery,

Life Time approx. 10 years

Withstanding voltage:

Between primary terminal and secondary terminal:
1500V AC for 1 min.

Between primary terminal and ground terminal:
1500V AC for 1 min.

Between ground terminal and secondary terminal:
1500V AC for 1 min.

Between secondary terminals:
500V AC for 1 min.

(primary terminal: Power supply, Relay output
secondary terminal: Analogue input/output, Voltage pulse output, contact input.)

Isolation Resistance: Between power supply terminal and ground 500V DC 20M Ω or more

Grounding: Class D grounding (grounding resistance of 100 Ω or less)

Isolation Specifications

Measured input terminal 1:

Isolated from Measured input terminal 2 and other input/output terminals. Not isolated from internal circuits.

Measured input terminal 2:

Isolated from Measured input terminal 1, other input/output terminals and internal circuits.

Auxiliary analogue input terminal:

Isolated from other input/output terminals and internal circuits.

Control output (current output or voltage pulse output) and retransmission output: Not isolated between control output and retransmission output terminals. Isolated from other input/output terminals and internal circuits.

Relay contact control output terminals:

Isolated from other input/output terminals and input circuits.

Contact input terminals:

Not isolated from other contact input and communication terminals.

Isolated from other input/output terminals and internal circuits.

Relay contact alarm output terminals:

Not isolated between other Relay contact alarm output terminals. Isolated from other input/output terminals and internal circuits.

Transistor contact alarm output terminals:

Not isolated between other transistor contact alarm output terminals. Isolated from other input/output terminals and internal circuits.

RS-485 communication terminals:

Not isolated between other communication terminals, and from contact input terminals.

Isolated from other input/output terminals and internal circuits.

Feedback slidewire resistance input terminals:

Not isolated from control output (current or voltage pulse), and retransmission output terminals. Isolated from other input/output terminals and internal circuits.

Power supply terminals:

Isolated from other input/output terminals and internal circuits.

Ground terminal:

Isolated from other input/output terminals and internal circuits.

● Environmental Conditions

Normal operating conditions:

Ambient temperature: 0 to 50°C (40°C or less in close mounting side-by-side)

Temperature change rate limit: 10°C/h or less

Ambient humidity: 20 to 90%RH (no condensation)

Magnetic field: 400 A/m or less

Continuous vibration (5 to 14Hz): Peak-to-peak amplitude 1.2mm or less

Continuous vibration (14 to 150Hz): 4.9m/s² or less

Vibration in short period: 14.7m/s², 15s or less

Shock: 147m/s² or less, 11ms

Installation Altitude: 2000m above the sea level or less

Warm-up time: 30 minutes or more

Transportation/storage conditions:

Temperature: -25 to 70°C

Temperature change rate limit: 20°C/h or less

Humidity: 5 to 95%RH (no condensation)

Effects of operating conditions:

Effect of ambient temperature:

For Voltage/TC input: Within $\pm 1\mu\text{V}/^\circ\text{C}$ or $\pm 0.01\%$ of F.S./ $^\circ\text{C}$, whichever is greater.)

For Auxiliary input: Within $\pm 0.02\%$ of F.S./ $^\circ\text{C}$

For RTD input: Within $\pm 0.05^\circ\text{C}/^\circ\text{C}$ (ambient temperature) or less

For analogue output: Within $\pm 0.05\%$ of F.S./ $^\circ\text{C}$ or less

Effect of power supply fluctuation (within rated voltage):

For analogue input: Within $\pm 1\mu\text{V}/10\text{V}$ or $\pm 0.01\%$ of F.S./10V, whichever is greater.)

For analogue output: Within $\pm 0.05\%$ of F.S./10V

Function Block Diagram for Single-loop Control

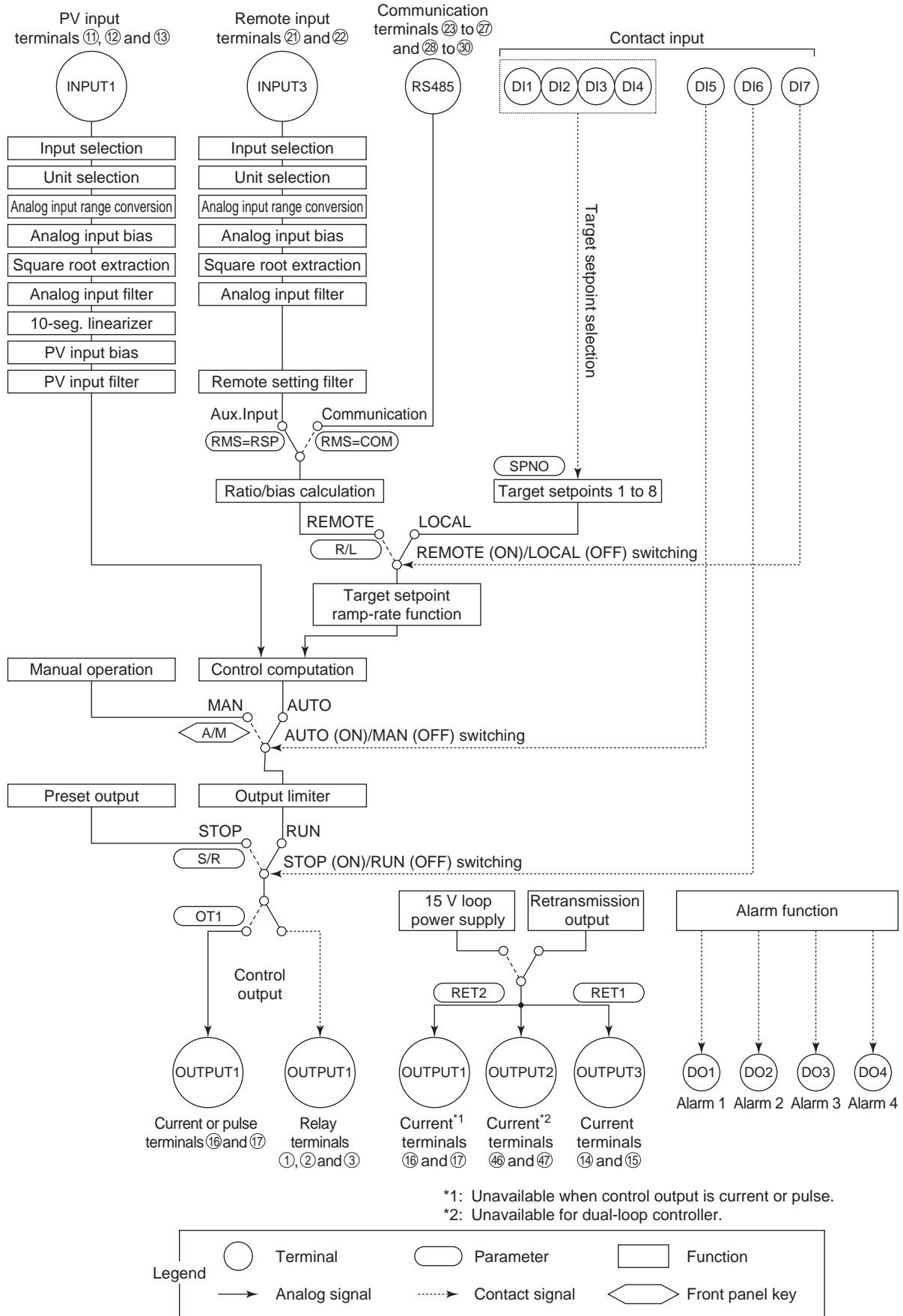

*1: Unavailable when control output is current or pulse.
 *2: Unavailable for dual-loop controller.

Function Block Diagram for Dual-loop Control

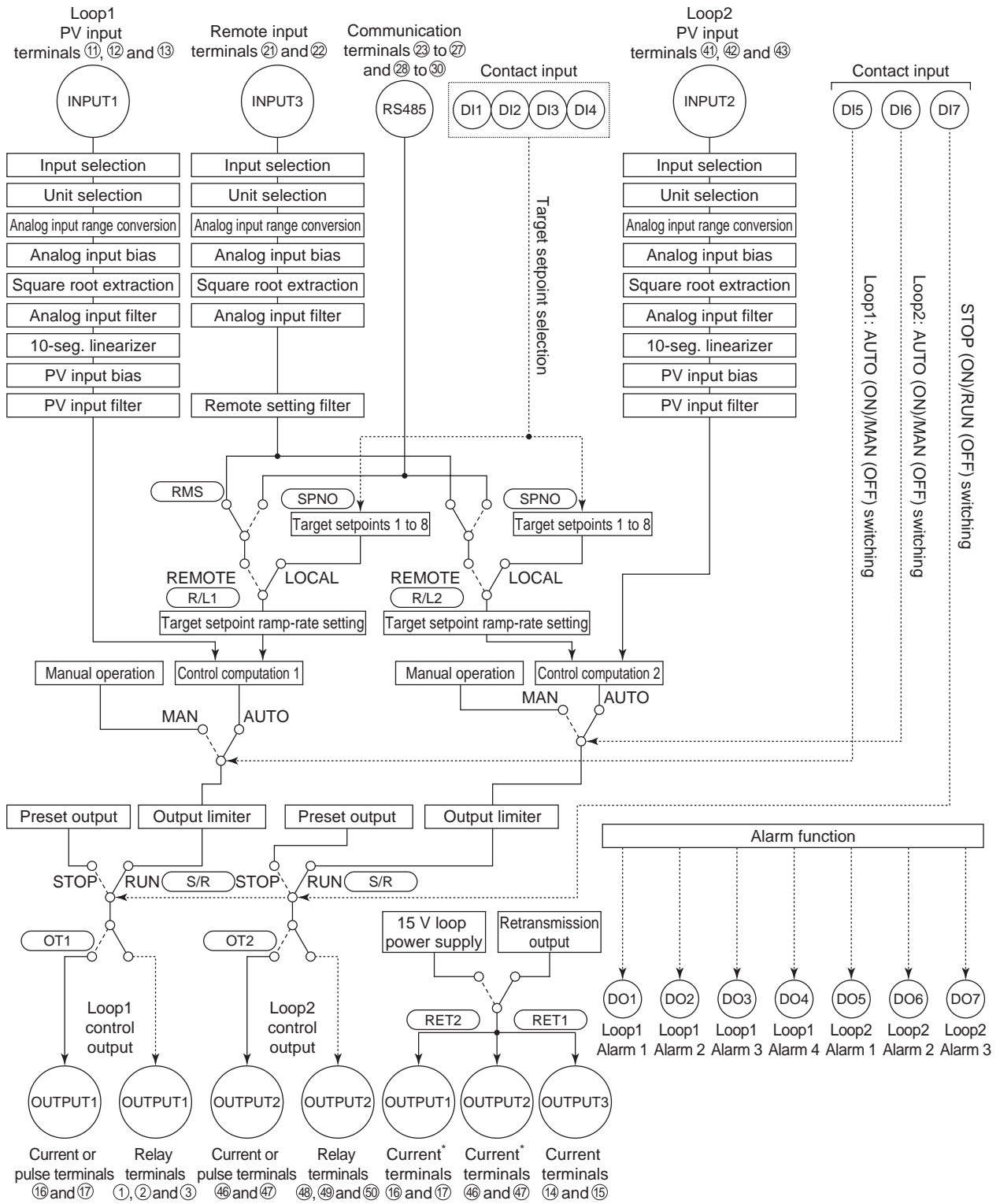

* : Unavailable when control output is current or pulse.

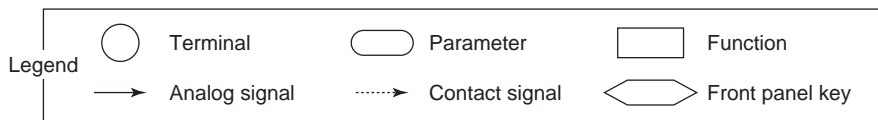

■ Function Block Diagram for Custom Computation

The UT750 controller comes with built-in control functions and various controller modes (UT modes) that provide different I/O computing functions. These modes are designed to support their respective control applications. From these choices, you can choose one that best meets your application needs.

In some control applications, however, you may want to execute special computations based upon specific input data or have a contact output of a specific data item in a specific control sequence. To be able to meet these needs, the UT750 controller provides a separate controller mode with which you can freely program your own computations. Computing functions available in these modes are referred to as custom computations.

Custom computations allow you to perform a variety of calculations based on input and output signals. These calculations include not only the four arithmetic operations and logical operations but also ten-segment linear approximations, temperature and humidity computations, temperature-based correction coefficient computations, pressure-based correction coefficient computations, and so on.

For example, you can use the four arithmetic operations to apply the desired type of correction to input signals, or use a logical operation to program a sequencing process that works between input and output contacts.

Custom computations are configured using the given methods of block connection, as shown in Figures below.

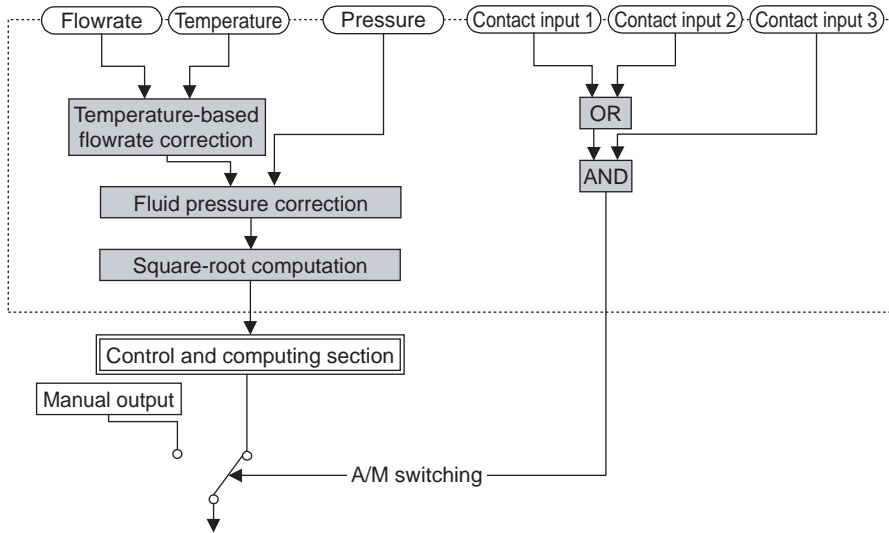

Custom Computations Applied to Input Signals

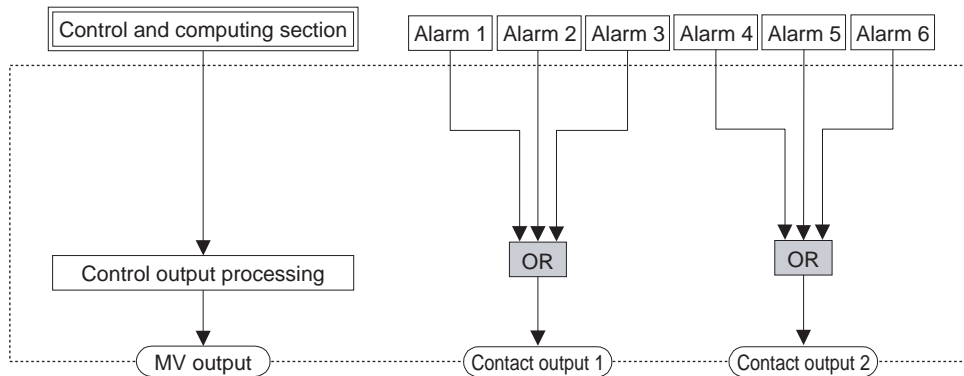

Custom Computations Applied to Output Signals

UT750 Single-loop Control (Model UT750-0□ or UT750-5□), Terminal Arrangements

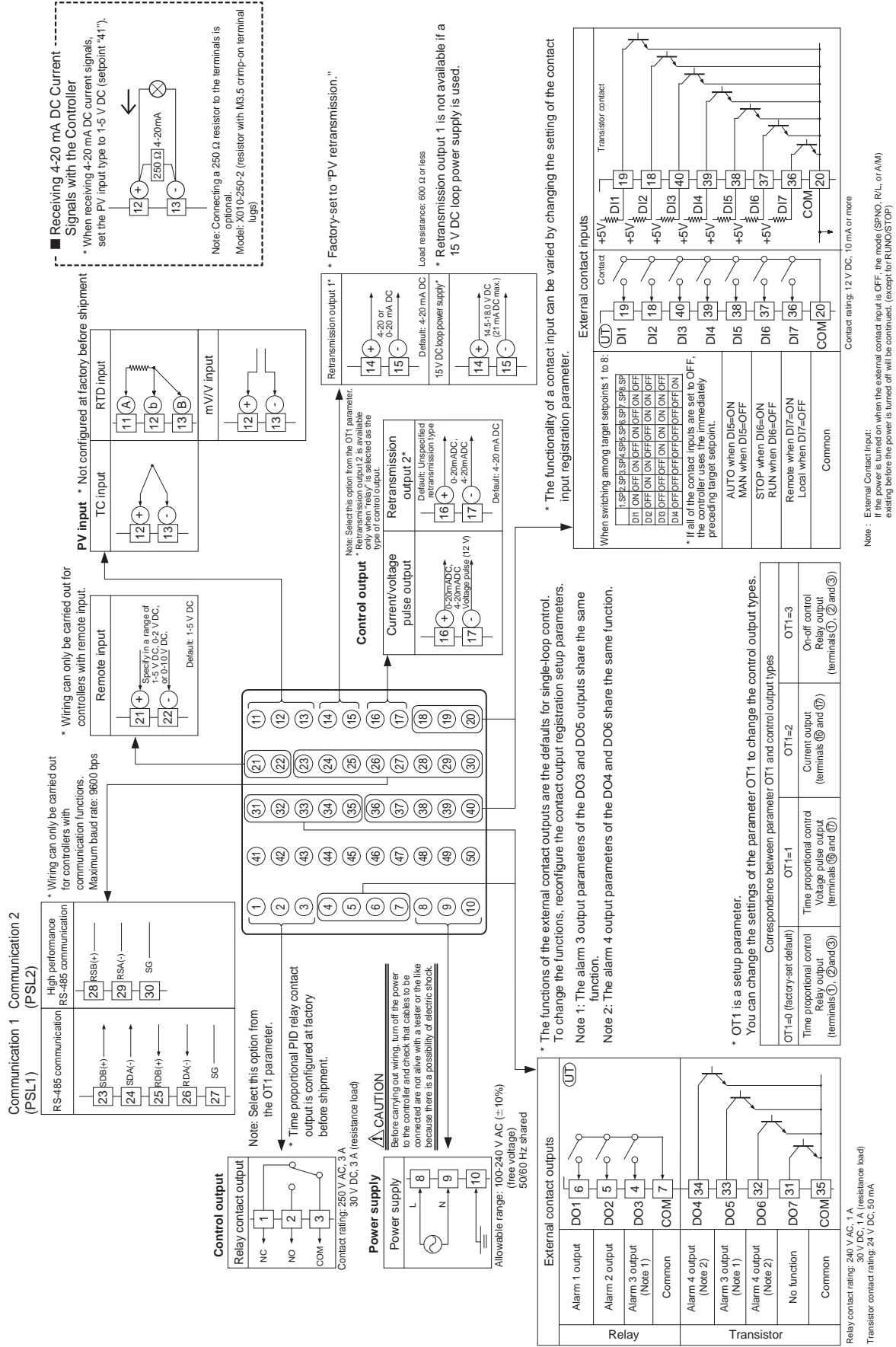

UT750 Dual-loop Control (Model UT750-5□), Terminal Arrangements

Loop2 PV input * Factory-set to "TC type-K"

TC input

mV/V input

Loop1 PV input * Not configured at factory before shipment.

RTD input

mV/V input

Loop2 control output

Continuous/voltage pulse output

Relay contact output

Retransmission output 2*

Retransmission type

Default: Unspecified retransmission type

0-20mA DC

0-20mA DC

4-20mA DC

4-20mA DC

Default: 4-20 mA DC

Loop1 control output

Relay contact output

Retransmission output 1*

Retransmission type

Default: 4-20 mA DC

4-20 mA DC

0-20 mA DC

0-20 mA DC

15 V DC loop power supply*

Load resistance: 600 Ω or less

* Retransmission output 1 is not available if a 15 V DC loop power supply is used.

Communication 1 (PSL1)

RS-485 communication

23 RSB(+)

24 SDA(+)

25 RDB(+)

26 RDA(+)

27 SG

Communication 2 (PSL2)

High performance RS-485 communication

28 RSB(+)

29 RSK(+)

30 SG

Remote input

Specify in a range of 1.5 V DC, 0.2 V DC, or 0-10 V DC.

Default: 1-5 V DC

(Both Loop1 and Loop2)

Loop1 control output

Current/voltage pulse output

Retransmission type

Default: Unspecified retransmission type

0-20mA DC

4-20mA DC

15 V DC loop power supply*

Load resistance: 600 Ω or less

* Retransmission output 1 is not available if a 15 V DC loop power supply is used.

Power supply

Power supply

Allowable range: 100-240 V AC (±10%) (free voltage)

50/60 Hz shared

External contact outputs

Loop1 alarm 1 output	DO1 6	Loop1 alarm 4 output	DO4 34
Loop1 alarm 2 output	DO2 5	Loop2 alarm 1 output	DO5 33
Loop1 alarm 3 output	DO3 4	Loop2 alarm 2 output	DO6 32
Common	COM 7	Loop2 alarm 3 output	DO7 31
Common	COM 7	Common	COM 35

Relay contact rating: 248 V AC, 1 A (resistance load)
Transistor contact rating: 24 V DC, 50 mA

External contact inputs

When switching among target setpoints 1 to 8; (Both Loop1 and Loop2)

D11 ON/OFF	ON/OFF	ON/OFF	ON/OFF	ON/OFF	ON/OFF	ON/OFF	ON/OFF
D12 OFF	ON/OFF	ON/OFF	ON/OFF	ON/OFF	ON/OFF	ON/OFF	ON/OFF
D13 OFF	ON/OFF	ON/OFF	ON/OFF	ON/OFF	ON/OFF	ON/OFF	ON/OFF
D14 OFF	ON/OFF	ON/OFF	ON/OFF	ON/OFF	ON/OFF	ON/OFF	ON/OFF

* All of the contact inputs are set to OFF, if the contact input is set to OFF, the preceding target setpoint.

Loop1 AUTO when DIS=ON	Loop1 MAN when DIS=OFF	Loop2 AUTO when DIG=ON	Loop2 MAN when DIG=OFF	STOP when DIT=ON	RUN when DIT=OFF	(Both Loop1 and Loop2)	Common
------------------------	------------------------	------------------------	------------------------	------------------	------------------	------------------------	--------

Note: External Contact Input
If the power is turned on when the external contact input is OFF, the mode (SPNO, R/L, or A/M) existing before the power is turned off will be continued, (except for RUN/STOP)

■ External Dimensions and Panel Cutout Dimension

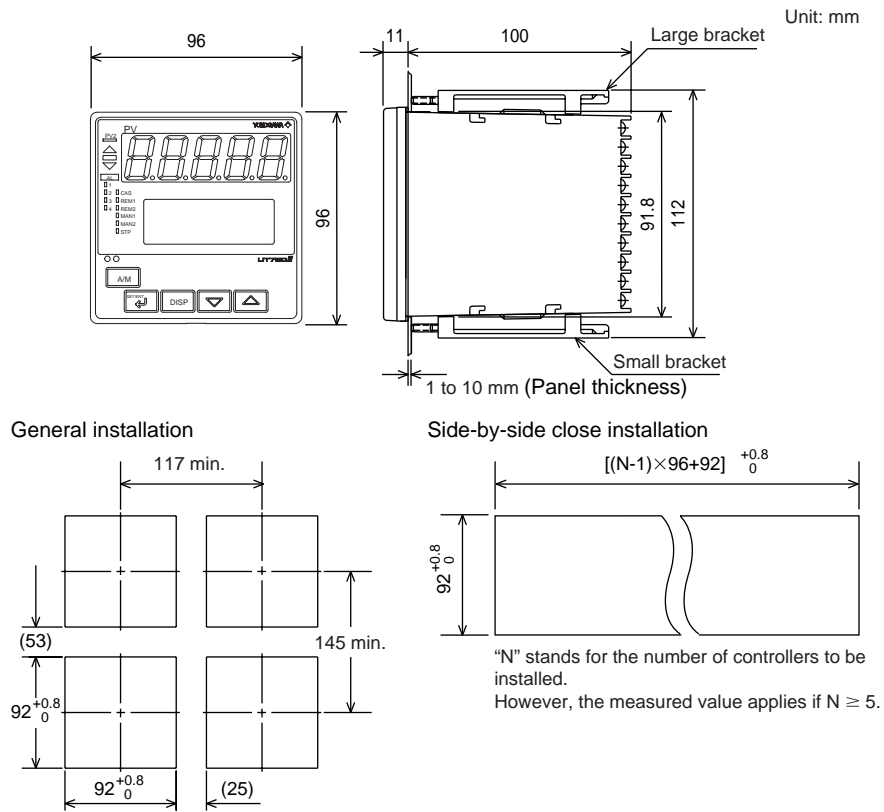

Normal Allowable Deviation=± (Value of JIS B 0401-1999 tolerance grade IT18) /2

■ Model and Suffix codes

Model Code	Suffix & Optional Suffix Code	Description
UT750	-□□	Digital indicating controller (provided with Custom Computing Function)
Type	-0 -1 -5	Single-loop type Position proportional type Dual-loop type
Optional functions	0 1	None With communication, auxiliary analog (remote) input

Note: Using an optional custom computation building tool (Model LL200-E10) that runs on a personal computer, you can build a variety of computation (eg., four arithmetic operations, logical operations, ten-segment linearizer computations, temperature compensation factor computations, and pressure compensation factor computations) to be applied to the controller's I/O signals.

Standard accessories: Brackets (mounting hardware), unit label, User's Manuals, and User's Manual (reference) (CD-ROM version).

Specify suffix code according to the designated UT mode.

Correspondence between UT mode and suffix code

UT mode	Suffix code →	00	01	10	11	50	51	Remarks
Single-loop control	(UT mode 1)	Cond.	App.	Cond.	App.	Cond.	App.	Cond.=Remote setpoint is not available
Cascade primary-loop control	(UT mode 2)	N/A	Cond.	N/A	N/A	N/A	App.	Cond.=Remote setpoint is not available
Cascade secondary-loop control	(UT mode 3)	N/A	App.	N/A	App.	N/A	App.	
Cascade control	(UT mode 4)	N/A	App.	N/A	App.	N/A	App.	The measured input 2 would be Aux.analogue input
Loop control for backup	(UT mode 5)	N/A	App.	N/A	App.	N/A	App.	
Loop control with PV switching	(UT mode 6)	N/A	App.	N/A	App.	N/A	App.	
Loop control with PV auto-selector	(UT mode 7)	N/A	App.	N/A	App.	N/A	App.	
Dual-loop control	(UT mode 11)	N/A	N/A	N/A	N/A	Cond.	App.	Cond.=Remote setpoint is not available
Temperature and humidity control	(UT mode 12)	N/A	N/A	N/A	N/A	Cond.	App.	Cond.=Remote setpoint is not available
Cascade control with two universal inputs(UT mode 13)		N/A	N/A	N/A	N/A	Cond.	App.	Cond.=Remote setpoint is not available
Loop control with PV switching and two universal inputs (UT mode 14)		N/A	N/A	N/A	N/A	Cond.	App.	Cond.=Remote setpoint is not available
Loop control with PV auto-selector and two universal inputs (UT mode 15)		N/A	N/A	N/A	N/A	Cond.	App.	Cond.=Remote setpoint is not available when two measured inputs are specified as an auto-selector. App.=Remote setpoint is not available when three measured inputs are specified as an auto-selector.
Custom computation control	(UT mode 21)	App.	App.	App.	App.	App.	App.	

App.: Function available, Cond.: Function available conditionally, N/A: Function not available

Digital I/O expansion module

Model	Description
P2ER1-20J+A	AC power supply Inputs (8 points) and relay outputs (8 points)
P2ET1-20J+A	AC power supply Inputs (8 points) and transistor outputs (8 points)

Note 1: Digital I/O expansion modules manufactured by Yokogawa Electric Corporation. Please order to Yokogawa Electric Corporation.

Note 2: Digital I/O expansion modules do not have CE/UL marking.

■ Items to be specified when ordering

Model & suffix code, necessary/unnecessary of User's Manual or QIC.